

Pre-heats fresh air for ventilation.

Features:

- High efficiency EC motor for electrical savings
- Up to three speeds if multiple exhaust devices are present
- Each speed is field programmable from 1%-100% of rated airflow.
- Temperature adjustable controls for setting delivered air temperature through simple on/off operation of the pump(s). (or optional variable speed pump).
- Includes internally mounted coil and pump.
- 120 volt, 1 ph., less than 12 amps.
- Field supplied motorized damper, filter rack and filter.
- Multi-positional: upflow, downflow and horizontal.
- Fresh air inlet from back, left, right or bottom.
- Cold weather models include extra externally mounted, cased coil and pump.

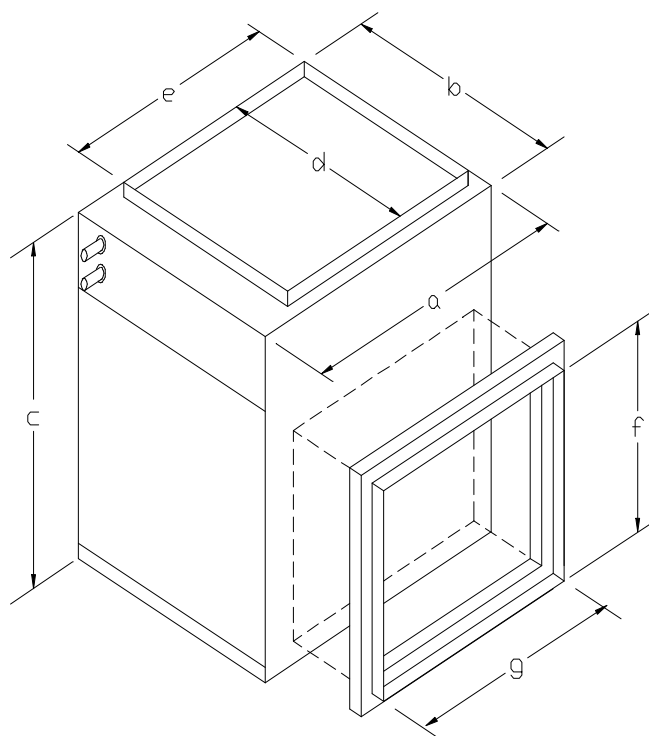

Moderate Climate (-4°F or -30°C)	Amps	Maximum Airflow (cfm)
MUA800-EC	4	800
MUA1400-EC	6	1400

Cold Climate	Amps	Maximum Airflow (cfm)
MUA700C-EC	4	700
MUA1300C-EC	6	1300

Physical Properties

120 volt, 1 ph., less than 12 amps

Catalogue No.		Cabinet dimensions (in.)			Supply air	Return air	Shipping info.	
		w	d	h			Weight (lb.)	Dimensions
MUA800		14	20	24	12"x16"	14"x18"	75	15"x23"x27"
MUA1400		22	25	29.5	20"x20"	18"x23"	115	23"x25"x32"
MUA700C	fan box	14	20	24	12"x16"	14"x18"	75	15"x23"x27"
	slab coil	5	23	18	12"x16"	14"x18"	22	6"x15"x24"
MUA1300C	fan box	22	25	29.5	20"x20"	18"x23"	115	23"x25"x32"
	slab coil	5	25	22	20"x20"	18"x23"	32	6"x23"x26"

Minimum Boiler Capacity Required in MBH

Outdoor Design Air Temp.		MUA800 ¹	MUA1400 ¹	MUA700C ²	MUA1300C ²	
-5°C	23°F	42	74	37	68	
-10°C	14°F	50	87	44	81	
-15°C	5°F	58	101	50	94	
-20°C	-4°F	65	114	57	106	
-25°C	-13°F	70	122	64	119	
-30°C	-22°F	78	136	71	131	
-35°C	-31°F	86*	150*	78	144	
-40°C	-40°F	93*	163*	84	157	
-45°C	-49°F	N/R**	N/R**	91	169	
-50°C	-58°F	N/R**	N/R**	98	182	

1. MUA800 and MUA1400 based on 30% glycol and 160F minimum boiler water temperature.

* 50% glycol recommended below -20C

2. MUA700C and MUA1300C based on 50% glycol and 140F minimum boiler water temperature.

** Airflow derating required at lower design temperatures, contact factory.